

Application Guide

PA 800 *plus* **Pharmaceutical Analysis** **System**

SDS-MW Analysis



A51970AA
April 2009



Beckman Coulter, Inc.
4300 N. Harbor Blvd.
Fullerton, CA 92835



Application Guide
PA 800 *plus* Pharmaceutical Analysis System
SDS-MW Analysis
PN A51970AA (April 2009)

Copyright © 2009 Beckman Coulter, Inc.

Beckman Coulter, Inc. grants a limited non-exclusive license to the owner or operator of a PA 800 *plus* instrument to make a copy, solely for laboratory use, of any portion or all of the online help and electronic documents shipped with the PA 800 *plus* instrument.

Trademarks:

Following is a list of Beckman Coulter trademarks:

- Beckman Coulter®
- 32 Karat™

All other trademarks are the property of their respective owners.

Find us on the World Wide Web at:

www.beckmancoulter.com and www.CELeader.com

EC	REP
----	-----

Beckman Coulter Ireland Inc.
Mervue Business Park,
Mervue, Galway,
Ireland (353 91 774068)

Beckman Coulter do Brasil Com e Imp de Prod de Lab Ltda
Estr dos Romeiros, 220 - Galpao G3 - Km 38.5
zip code 06501-001 - Sao Paulo - SP - Brasil
CNPJ: 42.160.812/0001-44

製造販売元：ベックマン・コールター株式会社
東京都江東区有明二丁目5番7号

生产商：
贝克曼库尔特有限公司，美国加利福尼亚州富勒顿市，
邮编：92835，电话：(001) 714-871-4848

Revision History

Initial Issue, A51970AA, April 2009

32 Karat Software version 9.1

PA 800 *plus* Software version 1.1

PA 800 *plus* Firmware version 9.0

Safety Notices

Symbols and Labels

Introduction

The following is a description of symbols and labels used on the Beckman Coulter PA 800 *plus* Pharmaceutical Analysis System or shown in this manual.



If the equipment is used in a manner not specified by Beckman Coulter, Inc., the protection provided by the instrument may be impaired.

General Biohazard Symbol

This caution symbol indicates a possible biohazard risk from patient specimen contamination.



Caution, Biohazard Label

This caution symbol indicates a caution to operate only with all covers in position to decrease risk of personal injury or biohazard.



Caution, Moving Parts Label

This caution symbol warns the user of moving parts that can pinch or crush.



High Voltage Electric Shock Risk Symbol

This symbol indicates that there is high voltage and there is a risk of electric shock when the user works in this area.

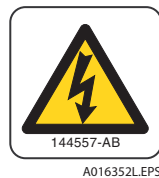

Class 1 Laser Caution Label

A label reading "THIS PRODUCT CONFORMS TO APPLICABLE REQUIREMENTS OF 21 CFR 1040 AT THE DATE OF MANUFACTURE" is found near the Name Rating tag. The laser light beam is not visible.



Sharp Object Label

A label reading "CAUTION SHARP OBJECTS" is found on the PA 800 plus.



Recycling Label

This symbol is required in accordance with the Waste Electrical and Electronic Equipment (WEEE) Directive of the European Union. The presence of this marking on the product indicates:

1. The device was put on the European Market after August 13, 2005.
2. The device is not to be disposed of via the municipal waste collection system of any member state of the European Union.

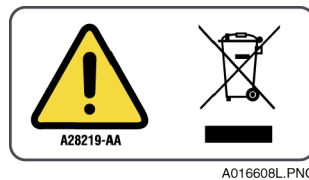

It is very important that customers understand and follow all laws regarding the proper decontamination and safe disposal of electrical equipment. For Beckman Coulter products bearing this label, please contact your dealer or local Beckman Coulter office for details on the take back program that facilitates the proper collection, treatment, recovery, recycling, and safe disposal of this device.

Disposal of Devices Containing Mercury Components

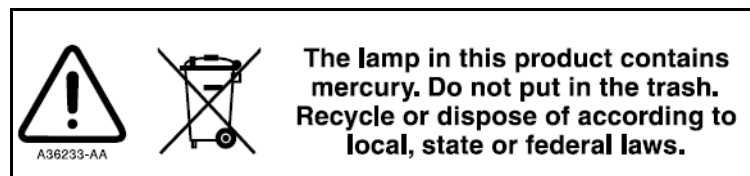

This product contains a mercury-added part. Recycle or dispose of according to local, state, or federal laws. It is very important that you understand and comply with the safe and proper disposal of devices containing mercury components (switch, lamp, battery, relay, or electrode). The mercury component indicator label can vary depending on the type of device.

Restriction of Hazardous Substances (RoHS) Labels

These labels and materials declaration table (the Table of Hazardous Substance's Name and Concentration) are to meet People's Republic of China Electronic Industry Standard SJ/T11364-2006 "Marking for Control of Pollution Caused by Electronic Information Products" requirements.

RoHS Caution Label

This logo indicates that this electronic information product contains certain toxic or hazardous elements, and can be used safely during its environmental protection use period. The number in the middle of the logo indicates the environmental protection use period for the product. The outer circle indicates that the product can be recycled. The logo also signifies that the product should be recycled immediately after its environmental protection use period has expired. The date on the label indicates the date of manufacture.



RoHS Environmental Label

This logo indicates that the product does not contain any toxic or hazardous substances or elements. The "e" stands for electrical, electronic and environmental electronic information products. This logo indicates that this electronic information product does not contain any toxic or hazardous substances or elements, and is green and is environmental. The outer circle indicates that the product can be recycled. The logo also signifies that the product can be recycled after being discarded, and should not be casually discarded.



Alerts for Warning, Caution, Important, and Note

WARNING

WARNING indicates a potentially hazardous situation which, if not avoided, could result in death or serious injury. The warning can be used to indicate the possibility of erroneous data that could result in an incorrect diagnosis (does not apply to all products).

CAUTION

CAUTION indicates a potentially hazardous situation, which, if not avoided, may result in minor or moderate injury. It may also be used to alert against unsafe practices. The caution can be used to indicate the possibility of erroneous data that could result in an incorrect diagnosis (does not apply to all products).

IMPORTANT **IMPORTANT** is used for comments that add value to the step or procedure being performed. Following the advice in the **IMPORTANT** notice adds benefit to the performance of a piece of equipment or to a process.

NOTE **NOTE** is used to call attention to notable information that should be followed during installation, use, or servicing of this equipment.

Revision History, iii

Safety Notices, v

CHAPTER 1: SDS-MW Analysis Kit, 1-1

Introduction, 1-1

Protein Size Standard, 1-2

Internal Standard, 1-2

Materials and Reagents, 1-2

Storing the Assay Components, 1-3

Reagents, 1-3

Materials Required but Not Provided by Beckman Coulter, 1-3

Beckman Coulter Consumables, 1-3

Preparing the PA 800 Instrument, 1-4

Installing the Capillary, 1-4

Cleaning the Interface, 1-4

Inserting the Cartridge/Calibrating the PDA, 1-5

Sample Preparation, 1-5

Preparation of SDS-MW Size Standard, 1-5

Preparation of Protein Sample, 1-5

Preparing Alkylation Reagent, 1-7

Sample Vial Setup, 1-8

Buffer Vial Preparation and Loading, 1-9

Preparing the Reagent Vials, 1-9

Tray Configuration, 1-11

Inlet Buffer Tray, 1-11

Outlet Buffer Tray, 1-12

Running the Assay, 1-13

Launching the SDS MW Instrument, 1-13

Conditioning a New Capillary, 1-13

Running SDS-MW Size Standard and Test Samples, 1-15

Checking the Separation Results, 1-17
 Estimating Protein Molecular Weights, 1-17
Troubleshooting Guide, 1-19

CHAPTER 2: Method Information, 2-1

Instrument and Detector Initial Conditions, 2-1
 Instrument Initial Conditions (All Methods), 2-1
 Detector Initial Conditions (All Methods), 2-2
 Capillary Conditioning Method (SDS MW Conditioning - PA 800 plus.met), 2-2
 SDS-MW Separation Method, 2-3
 Shutdown Method, 2-3

SDS-MW Analysis Kit

Introduction

Capillary electrophoresis (CE) has become an effective replacement for manual slab gel electrophoresis processes due to its automation, quantitation, fast speed and high efficiency. Many biomolecules, such as proteins, carbohydrates and nucleic acids are separated by molecular sieving electrophoresis using gel matrices, a technique referred to as capillary gel electrophoresis (CGE). The separation results from analytes' differential migration through a gel matrix. In this case, smaller molecules will move faster than large molecules through the separation gel. For polypeptides and proteins, it is necessary to denature the sample in the presence of SDS, an anionic detergent that binds the proteins in a constant ratio of 1:1.4 of protein. The constant mass-to-charge property of the SDS-bound proteins allows separation according to differences in protein molecular weight.

The SDS-MW Analysis Kit is designed for the separation of protein-SDS complexes using a replaceable gel matrix. The gel is formulated to provide an effective sieving range of approximately 10 kDa to 225 kDa. Within this size range, the logarithm of protein molecular mass is linear with its reciprocal electrophoretic mobility. So the molecular weight of an unknown protein may be estimated from a standard curve of known protein sizes. This kit can also be used to quantify the amount of protein and to determine the purity of a protein product.

NOTE This application guide has been validated for use on the PA 800 *Enhanced* Systems and the PA 800 *plus* Pharmaceutical Analysis Systems.

NOTE The PA 800 series systems must be equipped with a photodiode array (PDA) detector to perform this assay.

IMPORTANT The SDS-MW Analysis Kit is for laboratory use only.



Refer to the Material Safety data Sheets (MSDS) information, available at www.BECKMANCoulter.com, regarding the proper handling of materials and reagents. Always follow standard laboratory safety guidelines.

Protein Size Standard

The SDS-MW Size Standard contains 10, 20, 35, 50, 100, 150, and 225 kDa proteins. The SDS-MW Size Standard is used to calibrate the gel to estimate the protein molecular weight of your sample. It also provides confirmation of the resolving power of your experiment.

Internal Standard

A 10 kDa protein is used as a mobility marker. The mobility of all protein samples are calculated relative to this mobility marker allowing for more accurate size estimation and analyte identification.

Materials and Reagents

Table 1.1 Contents of this Kit (reorder # 390953)

Component	Quantity
Capillary, 50 µm I.D. bare-fused silica	2
SDS-MW Gel Buffer - proprietary formulation, pH 8, 0.2% SDS	140 mL
SDS-MW Sample Buffer - 100 mM Tris-HCl pH 9.0, 1%SDS	50 mL
SDS-MW Size Standard (10 to 225 kDa, 16 mg/mL)	100 µL
Internal Standard, 10 kDa, protein 5mg/mL	0.4 mL
Acidic Wash Solution (0.1 N HCl)	100 mL
Basic Wash Solution (0.1 N NaOH)	100 mL

Table 1.2 Replacement Reagents

Component	Quantity	Part Number
Capillary, 50 µm I.D. bare-fused silica	pkg of 3	338451
SDS-MW Gel Buffer - proprietary formulation, pH 8, 0.2% SDS	pkg of 4	A30341
SDS-MW Size Standard (10 to 225 kDa, 16 mg/mL)	pkg of 3	A22196
Internal Standard, 10 kDa protein, 5mg/mL	pkg of 1	A26487

Storing the Assay Components

Reagents

Upon receipt, store protein Sizing Standard and Internal Standard at 2°C to 8°C. The Capillary, Sample Buffer, and Gel Buffer can be stored at room temperature. If precipitation is noted in the Gel Buffer and Sample Buffer, stir until precipitation is completely dissolved.

Materials Required but Not Provided by Beckman Coulter

Component	Part Number
2-mercaptoethanol	Sigma-Aldrich, PN M7154, M6250
Water Bath (37°C to 100°C) or Heat Block	
Centricon YM-10 Centrifugal Filter Unit	Millipore, PN 4205
Iodoacetamide	Sigma-Aldrich, PN I-1149
Parafilm	
Sonicator	
Vortexer	
Pipets of various sizes with corresponding pipet tips	
Micro-centrifuge	

Beckman Coulter Consumables

Component	Part Number
0.5mL Micro-centrifuge Capped Vials (pack of 500)	344319
1.5 mL Centrifuge Tubes (pack of 500)	357448
Universal Plastic Vials (pack of 100)	A62251
Universal Rubber Vial Caps - blue (pack of 100) ^a	A62250
200 µL Micro Vials (pack of 50)	144709
Double-deionized (DDI) water	

a. Vial caps are one time use only and are not intended for re-use.

Preparing the PA 800 Instrument

NOTE Before proceeding, you must understand the following procedures as described in the PA 800 *plus* System Maintenance Guide (PN A51954AA):

- Capillary Replacement
- Installation of the PDA detector
- How to calibrate the PDA detector
- How to load and unload trays

Installing the Capillary

- 1** Install a 50 μm I.D. bare fused-silica capillary into a PA 800 cartridge set for a total capillary length of 30.2 cm.

The SDS-MW assay is optimized using a 30.2 cm capillary with a detection window of 20.0 cm from the sample introduction inlet.

- 2** Use the 100 x 200 μm capillary aperture for this installation.

To get good reproducibility from capillary to capillary and accurate mobility assignments, it is important to adhere to the capillary pre-measurement procedure.

NOTE The cut ends of capillaries should be inspected carefully under magnification. The cut must be clean (not jagged) and perpendicular to the capillary length (not angled). Poor cuts will result in poor resolution and poor sample loading.

- 3** Turn off the PA 800 instrument and install the PDA detection module.
-

- 4** Turn on the instrument and permit the UV lamp to warm up for at least 30 minutes, prior to experimentation.
-

Cleaning the Interface

Using a Kimwipe and DDI water, carefully clean the electrodes, capillary ends, and interface block after 120 runs or when changing chemistries on the PA 800 system. The SDS gel buffer is very viscous and will accumulate on the electrodes, capillary ends, opening levers, and interface block if regular and thorough cleaning is not employed. Gel accumulation may cause various modes of system failure, including broken capillaries and bent electrodes, vial jams, and missed injections.

Inserting the Cartridge/Calibrating the PDA

Insert the cartridge into the system. Close the front panel and calibrate the PDA detector. This procedure should be employed daily or any time the cartridge is replaced.

Sample Preparation

Preparation of SDS-MW Size Standard

- 1 Remove SDS-MW Size Standard from refrigerator. Leave at room temperature for 15 minutes before starting sample preparation.
- 2 Mix the standard thoroughly and centrifuge briefly in a standard microfuge.
- 3 Pipette 10 μ L of Size Standard into a micro-centrifuge vial.
- 4 Add 85 μ L of Sample Buffer into the micro-centrifuge vial.
- 5 Add 2 μ L of Internal Standard into the micro-centrifuge vial.
- 6 Add 5 μ L of 2-mercaptoethanol. Cap the vial tightly, seal with Parafilm, and mix thoroughly.
- 7 Heat mixture in a water bath at 100°C for three minutes.
- 8 Place the vial in a room-temperature water bath to cool for five minutes before injection. The sample will remain stable for approximately 24 hours.

Preparation of Protein Sample

Desalting the Protein Sample

The signal intensity and resolution of this kit are sensitive to the salt concentration in the protein sample. Generally, if the final salt concentration is above 50 mM, the sample loading efficiency will be reduced. The sample should be desalted with a Centricon column using the following procedure:

-
- 1 Add 1 mL of protein sample to a Centricon YM-10, then add 1 mL SDS-MW sample buffer into the Centricon.

 - 2 Centrifuge at 7,000 g for 20 minutes.

 - 3 Add 2 mL of sample buffer. Centrifuge at 7,000 g for 20 minutes.

 - 4 Insert the Centricon upside-down to drain the suspended protein solution (in the filter membrane) into a new vial and centrifuge for three minutes at 5,000 g.

 - 5 Transfer the collected protein to an appropriate sterile tube. Add sample buffer to give a final volume of 1 mL.
-

Protein Sample Concentration

After the addition of the SDS-MW Sample Buffer, the total protein concentration should be within the range of 0.2 mg/mL to 2 mg/mL. For best results, the recommended protein concentration is 1 mg/mL. If the protein concentration is too high, it can result in insufficient SDS binding, giving broad peaks and poor resolution. On the other hand, if the protein concentration is too low, a low signal will be observed.

Reducing the Protein Sample

Reduction of the disulfide bonds will provide a more accurate assessment of a protein's molecular weight and will allow you to gain additional structural information on a given protein. In this case:

-
- 1 Dilute the sample with the SDS-MW Sample buffer for a total 95 μ L volume to give a final protein concentration range of 0.2 mg/mL to 2 mg/mL.

 - 2 Add 2 μ L of Internal Standard.

 - 3 Add 5 μ L of 2-mercaptoethanol. Cap the vial tightly, seal with Parafilm, and mix thoroughly.

 - 4 Heat mixture in a water bath at 100°C for 3 minutes.

 - 5 Place the vial in a room-temperature water bath to cool for 5 minutes before injection.
-

Non-reduced Protein Sample Preparation

Comparison of a protein's reduced versus non-reduced state can yield important structural information. In this case it is a good idea to alkylate your protein sample to minimize any heterogeneity created from partial auto-reduction of your protein. The following procedure is recommended.

Preparing Alkylation Reagent

A 250 mM solution of iodoacetamide (IAM) is recommended as an alkylation reagent. The solution is stable for approximately 24 hours at room temperature.

- 1 Weigh out 46 mg of IAM and place in a micro-centrifuge vial.
- 2 Add 1 mL of DDI water to a sample vial. Cap the vial tightly and mix thoroughly.

Preparing the Sample

- 1 Dilute the sample with the SDS-MW Sample Buffer for a total 95 μ L volume to give a final protein concentration range of 0.2 mg/mL to 2 mg/mL.
- 2 Add 2 μ L of Internal Standard.
- 3 Add 5 μ L of IAM solution.
- 4 Cap the vial tightly, seal with Parafilm, and mix thoroughly.
- 5 Heat mixture in a water bath at 70°C for 3 minutes.
- 6 Place the vial in a room-temperature water bath to cool for 5 minutes before injection.

Sample Vial Setup

Before placing the 200 microliter sample vials (or micro vials) into the universal vials, ensure that no bubbles are at the bottom of the micro vials. If bubbles exist, centrifuge the micro vials for 2 minutes at 1,000 g and repeat if necessary. Place a blue cap on the universal vial and ensure a good seal, see [Figure 1.1](#).

Place the universal vials into the 48-position inlet sample tray from positions A1 through C8. For the best quantitative results, perform one injection per vial, introducing replicates in separate vials.

Figure 1.1 Sample Vial Setup

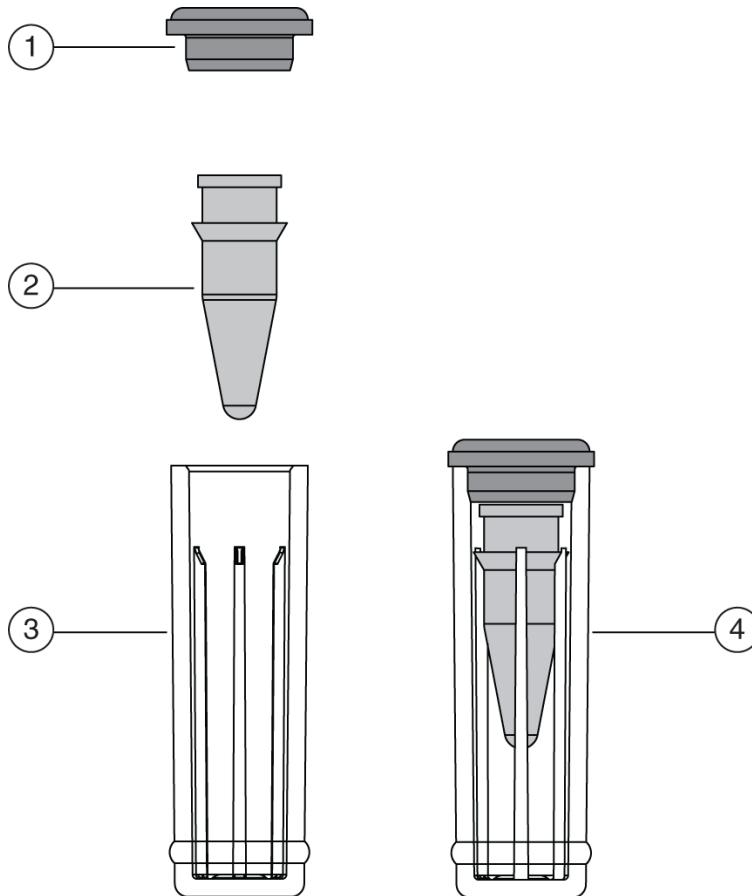

901927L.AI

1. Universal Cap
2. Micro Vial
3. Universal Vial
4. Micro Vial inside Universal Vial

Buffer Vial Preparation and Loading

Fill the appropriate number of reagent vials with the SDS-MW Gel Buffer, 0.1 N NaOH solution, 0.1 N HCl solution, and DDI water according to the [Tray Configuration](#) paragraphs.

The number of reagent vials is dependent upon the number of method cycles. The methods have been developed to automatically advance the reagent vials after eight cycles, providing a fresh set of buffers for every eight cycles run. The buffer tray templates illustrated in [Table 1.3, Inlet Buffer Tray Configuration](#) and [Table 1.4, Outlet Buffer Tray Configuration](#), are setup for use with high-resolution methods, which introduce the sample from the left side tray.

Preparing the Reagent Vials

- 1 Fill the gel rinse (Gel-R) vials with 1.2 mL of SDS-MW Gel Buffer. Fill the gel separation (Gel-S) vials with 1.1 mL of SDS-MW Gel Buffer.
- 2 Degas the SDS-MW Gel vials for five minutes, under 5 to 15 mm Hg vacuum.
- 3 Fill the water (H₂O) vials with 1.5 mL of DDI water.
- 4 Fill the NaOH and HCl rinse vials to 1.5 mL.

 **WARNING**

Pressure system damage can occur when the waste vial volume exceeds 1.8 mL.

- 5 Fill the waste vials with 0.8 mL of DDI water.

Figure 1.2 Fill the Reagent Vials

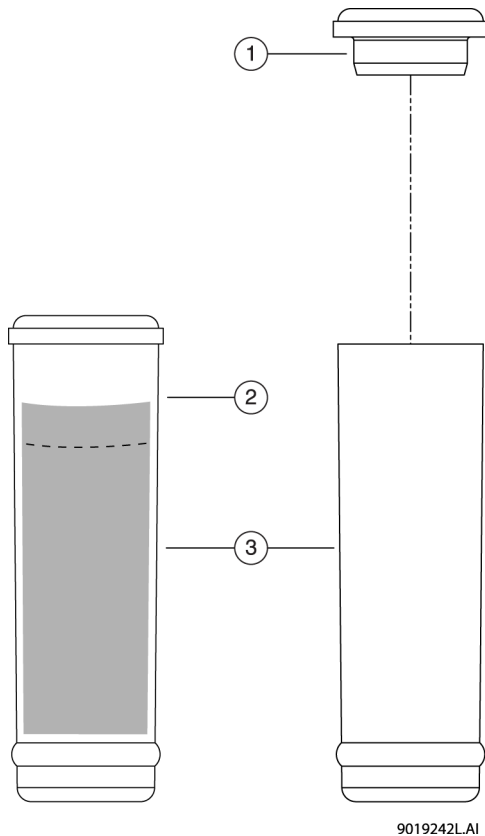

1. Universal Vial Cap
2. Maximum Fill Level
3. Universal Vials

NOTE Carefully fill the buffer vials with SDS-MW Gel Buffer without producing bubbles, within the volume recommended. If the volume is too low ($< \frac{1}{2}$ of vial volume), the capillary and electrode may not be able to dip into the SDS gel during the separation. On the other hand, if the filled volume is too high, the SDS-MW Gel Buffer may accumulate on the capillary ends, opening levers, and electrodes, causing various types of system failure.

6 Cap the universal vials with the blue caps.

IMPORTANT In this application, all vials and caps are designed for a maximum of eight runs each. Do not attempt to reuse the caps because they are often contaminated with dried gel and other chemicals.

Tray Configuration

1 Load the reagents into the system inlet (left) and outlet (right) 6x6 buffer trays using the configuration illustrated in [Table 1.3, Inlet Buffer Tray Configuration](#) and [Table 1.4, Outlet Buffer Tray Configuration](#).

2 Load the trays into the PA 800 system.

Inlet Buffer Tray

Table 1.3 Inlet Buffer Tray Configuration

H ₂ O (Cycle 17-24)	H ₂ O (Cycle 17-24)				
H ₂ O (Cycle 9-16)	H ₂ O (Cycle 9-16)				
H ₂ O (Cycle 1-8)	H ₂ O (Cycle 1-8)				
H ₂ O (Cycle 17-24)	Gel-R (Cycle 17-24)	Gel-S (Cycle 17-24)	NaOH (Cycle 17-24)	HCl (Cycle 17-24)	H ₂ O (Cycle 17-24)
H ₂ O (Cycle 9-16)	Gel-R (Cycle 9-16)	Gel-S (Cycle 9-16)	NaOH (Cycle 9-16)	HCl (Cycle 9-16)	H ₂ O (Cycle 9-16)
H ₂ O (Cycle 1-8)	Gel-R (Cycle 1-8)	Gel-S (Cycle 1-8)	NaOH (Cycle 1-8)	HCl (Cycle 1-8)	H ₂ O (Cycle 1-8)
A	B	C	D	E	F

A1 to A6: DDI H₂O, use for dip step to clean capillary tip, 1.5 mL
 B4 to B6: DDI H₂O, use for dip step to clean capillary tip, 1.5 mL
 B1 to B3: SDS-MW Buffer Gel (Gel-R) to fill capillary prior to each cycle, 1.2 mL
 C1 to C3: SDS-MW Gel Buffer for separation (Gel-S), 1.1 mL
 D1 to D3: 0.1N NaOH, use to precondition capillary, 1.5 mL
 E1 to E3: 0.1N HCl, use to precondition capillary, 1.5 mL
 F1 to F3: DDI H₂O, use to precondition capillary, 1.5 mL

Outlet Buffer Tray

Table 1.4 Outlet Buffer Tray Configuration

H ₂ O (Cycle 17-24)	H ₂ O (Cycle 17-24)				
H ₂ O (Cycle 9-16)	H ₂ O (Cycle 9-16)				
H ₂ O (Cycle 1-8)	H ₂ O (Cycle 1-8)				
H ₂ O (Cycle 17-24)	Waste (Cycle 17-24)	Gel-S (Cycle 17-24)	Waste (Cycle 17-24)	Waste (Cycle 17-24)	Waste (Cycle 17-24)
H ₂ O (Cycle 9-16)	Waste (Cycle 9-16)	Gel-S (Cycle 9-16)	Waste (Cycle 9-16)	Waste (Cycle 9-16)	Waste (Cycle 9-16)
H ₂ O (Cycle 1-8)	Waste (Cycle 1-8)	Gel-S (Cycle 1-8)	Waste (Cycle 1-8)	Waste (Cycle 1-8)	Waste (Cycle 1-8)
A	B	C	D	E	F

A1 to A6: DDI H₂O, use in dip step to clean capillary tip, 1.5 mL
 B4 to B6: DDI H₂O, use in dip step to clean capillary tip, 1.5L
 B1 to B3: Waste vial for SDS-MW Gel rinse, 0.8 mL of DDI water
 C1 to C3: SDS-MW Gel Buffer for separation (Gel-S), 1.1 mL
 D1 to D3: Waste vial for 0.1N NaOH rinse, 0.8 ml of DDI water
 E1 to E3: Waste vial for 0.1N HCl rinse, 0.8 ml of DDI water
 F1 to F3: Waste vial for DDI H₂O rinse, 0.8 ml of DDI water

Running the Assay

Launching the SDS MW Instrument

1 Launch 32 Karat software. The Enterprise screen will display the available instruments.

2 Double-click on the **SDS MW** instrument to launch the SDS-MW assay.

3 Select **SDS MW** as the project on the log in screen.

NOTE Type in **PA800** as the user name and type **Plus** as the password.

NOTE User Name and Password defaults have been established for installation and training purposes.

Conditioning a New Capillary

A new capillary needs to be conditioned once before use.

NOTE To help improve your system automation, a pre-programmed sequence is available for download. This sequence includes conditioning and separation runs for 24 samples. Visit www.celeader.com/sequences and select the **SDS MW - 24 samples - PA 800 plus** sequence.

1 To initiate the conditioning method, select **Control > Single Run** from the 32 Karat Menu bar. The Single Run Acquisition dialog opens.

Figure 1.3 Single Run Acquisition Dialog Box

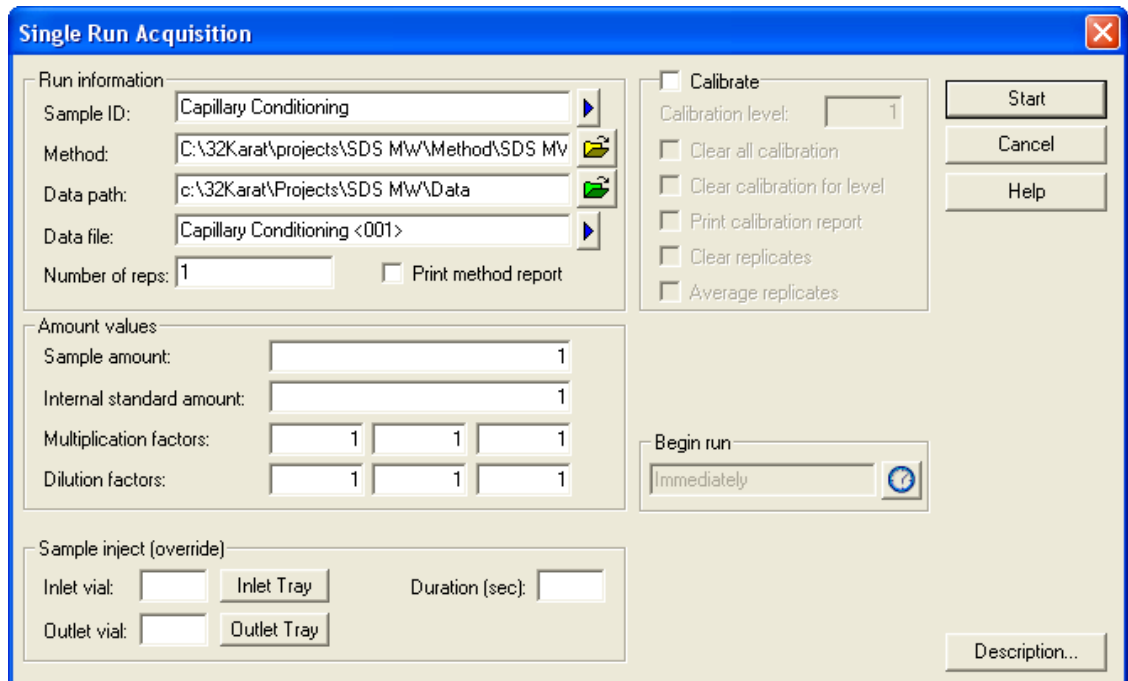

- 2 From the **Method** field, click on the **Folder** icon.
- 3 Select the **SDS MW Conditioning - PA 800 plus.met** file and specify the data filename of your choice.
- 4 Click on the **Arrow** button and select the **Increment** option.
- 5 Type **1** as the **Number of Reps**.
Since no sample will be injected, a vial injection position does not need to be specified.
- 6 Press **Start** to begin the conditioning process.

Running SDS-MW Size Standard and Test Samples

The sequence table is designed to automate the process of running size standard and samples. For your convenience a sequence template has been pre-programmed to run up to 24 unknown samples.

The sequence table has been designed this way to consider the automatic replacement of the assay reagents during the course of the experiment.

Once the buffer trays and samples have been loaded into the system, you are ready to begin the analysis of the test compounds.

NOTE Check the Beckman Coulter web site for the most current versions of pre-programmed sequences and methods for this assay.

- 1 On the Task bar, select **Control**, then **Sequence Run**. The Run Sequence dialog will open.
- 2 Select the **Folder** button to browse to the proper SDS MW sequence.
- 3 Set the **Run Range** to **All**.
- 4 Select **Start**.

Figure 1.4 Run Sequence Dialog Box

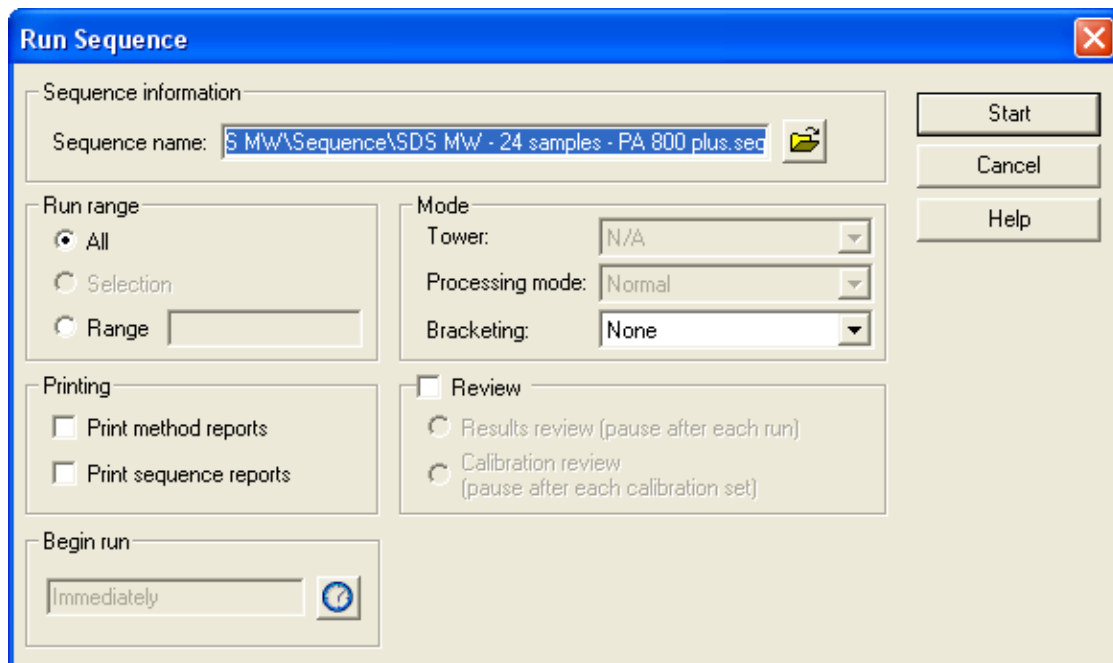

An example of the sequence template pre-programming to run one conditioning run, 24 samples and molecular weight size standards, as well as a shutdown method is shown in Figure 1.5.

The shutdown method should be run at the end of the experimentation. This method cleans the capillary and turns off the UV lamp.

Figure 1.5 Sequence Table for SDS MW

Run #	Status	Run Type	Reps	Sample Inject Inlet	Sample Inject Outlet	Sample Inject Duration	Sample ID	Method	Filename
1		Unknown	1					SDS MW Conditioning - PA 800 plus.met	Capillary Conditioning.dat
2		Summary Begin	1	SI:A1	BO:C1	20.0		SDS MW Separation - PA 800 plus.met	<D>.dat
3		Summary Run	1	SI:A2	BO:C1	20.0		SDS MW Separation - PA 800 plus.met	<D>.dat
4		Summary Run	1	SI:A3	BO:C1	20.0		SDS MW Separation - PA 800 plus.met	<D>.dat
5		Summary Run	1	SI:A4	BO:C1	20.0		SDS MW Separation - PA 800 plus.met	<D>.dat
6		Summary Run	1	SI:A5	BO:C1	20.0		SDS MW Separation - PA 800 plus.met	<D>.dat
7		Summary Run	1	SI:A6	BO:C1	20.0		SDS MW Separation - PA 800 plus.met	<D>.dat
8		Summary Run	1	SI:A7	BO:C1	20.0		SDS MW Separation - PA 800 plus.met	<D>.dat
9		Summary Run	1	SI:A8	BO:C1	20.0		SDS MW Separation - PA 800 plus.met	<D>.dat
10		Summary Run	1	SI:B1	BO:C2	20.0		SDS MW Separation - PA 800 plus.met	<D>.dat
11		Summary Run	1	SI:B2	BO:C2	20.0		SDS MW Separation - PA 800 plus.met	<D>.dat
12		Summary Run	1	SI:B3	BO:C2	20.0		SDS MW Separation - PA 800 plus.met	<D>.dat
13		Summary Run	1	SI:B4	BO:C2	20.0		SDS MW Separation - PA 800 plus.met	<D>.dat
14		Summary Run	1	SI:B5	BO:C2	20.0		SDS MW Separation - PA 800 plus.met	<D>.dat
15		Summary Run	1	SI:B6	BO:C2	20.0		SDS MW Separation - PA 800 plus.met	<D>.dat
16		Summary Run	1	SI:B7	BO:C2	20.0		SDS MW Separation - PA 800 plus.met	<D>.dat
17		Summary Run	1	SI:B8	BO:C2	20.0		SDS MW Separation - PA 800 plus.met	<D>.dat
18		Summary Run	1	SI:C1	BO:C3	20.0		SDS MW Separation - PA 800 plus.met	<D>.dat
19		Summary Run	1	SI:C2	BO:C3	20.0		SDS MW Separation - PA 800 plus.met	<D>.dat
20		Summary Run	1	SI:C3	BO:C3	20.0		SDS MW Separation - PA 800 plus.met	<D>.dat
21		Summary Run	1	SI:C4	BO:C3	20.0		SDS MW Separation - PA 800 plus.met	<D>.dat
22		Summary Run	1	SI:C5	BO:C3	20.0		SDS MW Separation - PA 800 plus.met	<D>.dat
23		Summary Run	1	SI:C6	BO:C3	20.0		SDS MW Separation - PA 800 plus.met	<D>.dat
24		Summary Run	1	SI:C7	BO:C3	20.0		SDS MW Separation - PA 800 plus.met	<D>.dat
25		Summary End	1	SI:C8	BO:C3	20.0		SDS MW Separation - PA 800 plus.met	<D>.dat
26		Shutdown	1					SDS MW Shutdown - PA 800 plus.met	Shutdown.dat
27									

Checking the Separation Results

The Protein Size Standard contains seven proteins (10, 20, 35, 50, 100, 150, and 225 kDa). All proteins should be completely separated within 30 minutes using our recommended method. See [Figure 1.6](#) for a typical separation of the Size Standard.

Figure 1.6 Separation of Protein Molecular Weight Size Standard

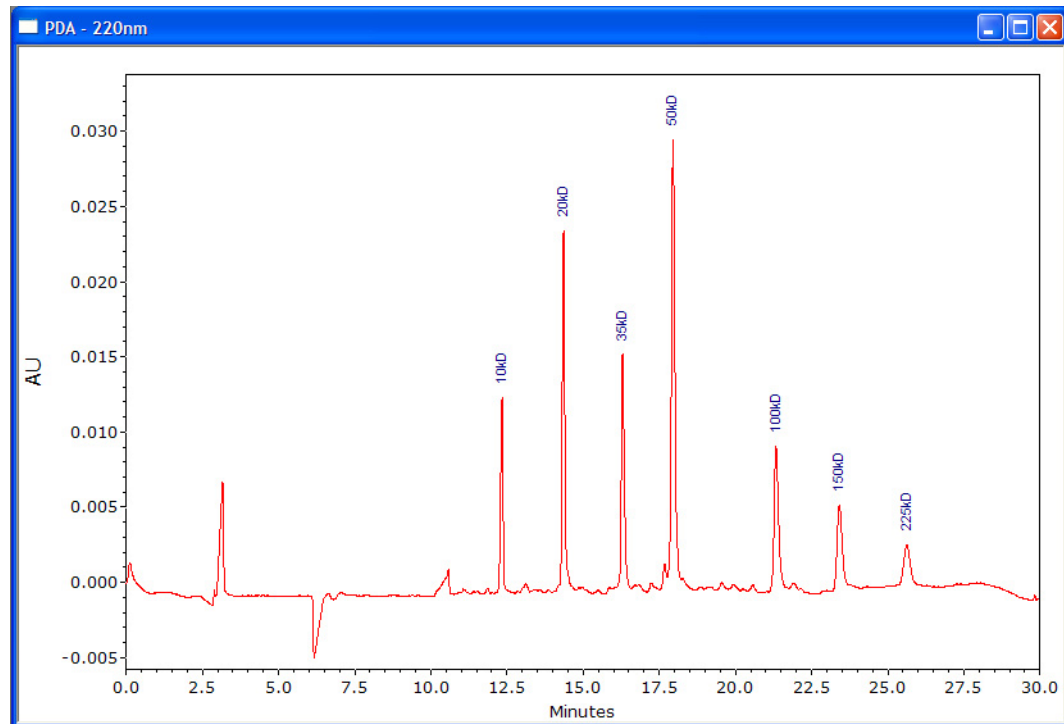

Estimating Protein Molecular Weights

A 10 kDa mobility marker is used as an internal reference standard and all the protein mobility is calculated relative to this internal standard. See [Figure 1.7](#) for a typical calibration curve obtained by plotting the Log of molecular weight vs. mobility of each protein in the protein Size Standard ($1/X$). The molecular weight of an unknown protein can be estimated by using this calibration curve. The calculated molecular weights are displayed in the electropherogram by selecting Quality as an annotation.

It is recommended that this curve be re-calibrated every 24 cycles. This is done by running the Size Standard and updating the mobility values for each standard to reflect the new run. This update is performed in the qualitative analysis of the 32 Karat Control and Analysis Software. See [Figure 1.7](#) below for an example of this set-up.

Figure 1.7 Qualitative Analysis Tab for Updating the Size Calibration Curve

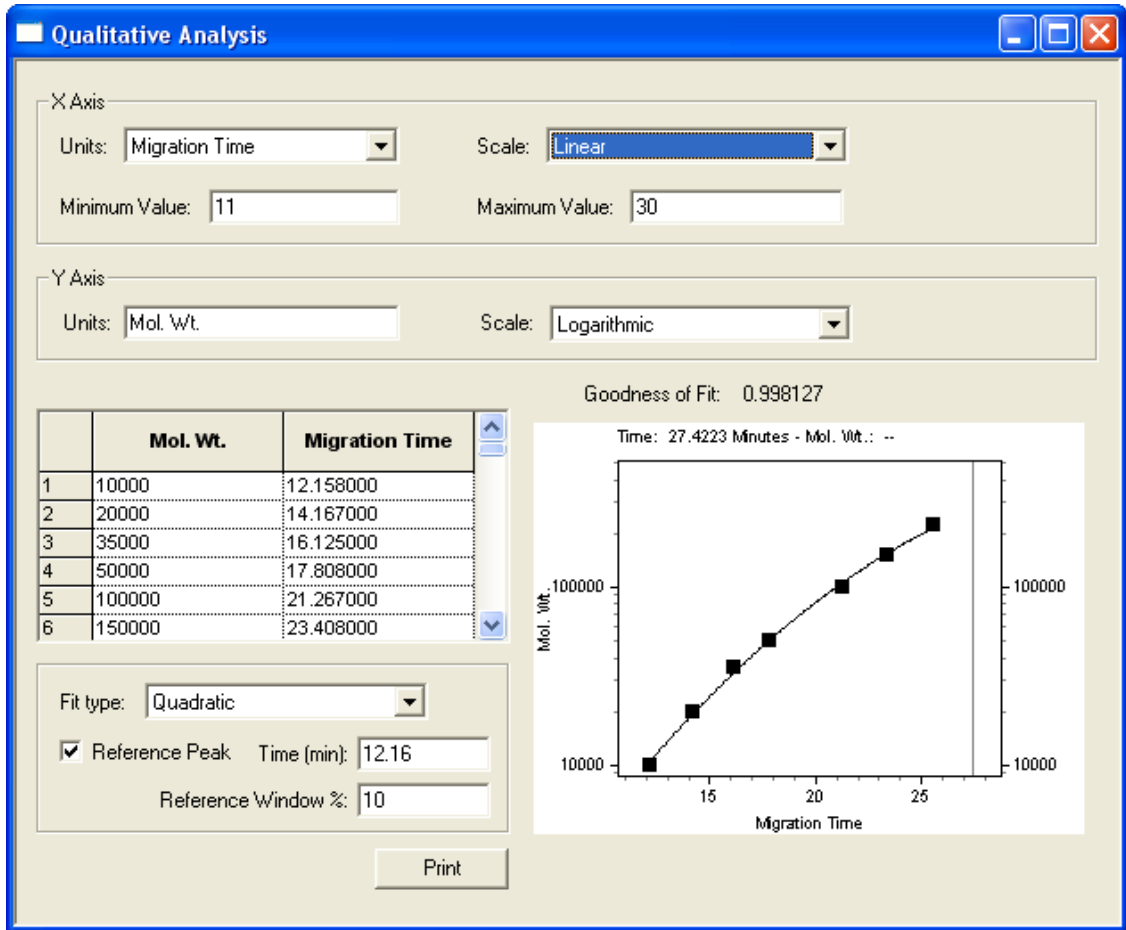

Troubleshooting Guide

Problem	Possible Cause	Corrective Action
Low or unsteady current	Capillary Plugged	(1) Rinse the capillary with DDI water at 100 psi for 10 minutes and then perform the capillary conditioning method. (2) If unsteady current still occurs after step (1), change to a new capillary.
	Air bubbles in the gel	1) Degas SDS-MW Gel Buffer under 5 to 15 Hg vacuum for 5 minutes.
High current	Contaminated Gel Buffer	Replace gel buffer as needed
	Contamination on electrode	Clean electrodes. Consult the System Maintenance Guide (A51964AA).
Spikes in electropherogram	Air bubbles in gel buffer	1) Degas SDS-MW Gel Buffer under 5 to 15 Hg vacuum for 5 minutes.
Broad peaks or low efficiency	Poor capillary end cut	Check the capillary end under 10x magnification. Re-cut the capillary end if the cut is not clean or is angled.
	Improper reduction of sample	Reduce sample using recommended procedure. Use fresh mercaptoethanol for sample reduction.
	High salt in protein sample	Buffer exchange the sample using recommended procedure.
	Deteriorated capillary	Replace capillary when other attempts to reduce peak broadening fail.
No peaks	Capillary inlet is longer than the inlet electrode.	Re-cut capillary inlet to make sure it is shorter than the electrode.
	Dirty or plugged capillary tip	(1) Clean capillary tip using DDI water. (2) Re-cut the tip if the capillary was partially plugged.
	Insufficient quantity of sample	Increase sample volume in the micro vial to 100 μ L.

Method Information

Instrument and Detector Initial Conditions

The instrument and detector initial conditions are the same for all SDS-MW methods.

Instrument Initial Conditions (All Methods)

Figure 2.1 Instrument Setup - Instrument Initial Conditions

The screenshot shows the 'Instrument Setup' dialog box with the 'Initial Conditions' tab selected. The dialog is divided into several sections:

- Auxiliary data channels:** Includes checkboxes for Voltage (unchecked, max: 30.0 kV), Current (checked, max: 300.0 µA), Power (unchecked), and Pressure (unchecked).
- Mobility channels:** Includes checkboxes for Mobility (unchecked), Apparent Mobility (unchecked), and Plot trace after voltage ramp (checked).
- Analog output scaling:** Factor is set to 1.
- Temperature:** Cartridge and Sample storage are both set to 25.0 °C.
- Peak detect parameters:** Threshold is set to 2, and Peak width is set to 9.
- Trigger settings:** Includes checkboxes for Wait for external trigger (unchecked), Wait until cartridge coolant temperature is reached (checked), and Wait until sample storage temperature is reached (checked).
- Inlet trays:** Buffer is set to 36 vials and Sample is set to 48 vials.
- Outlet trays:** Buffer is set to 36 vials and Sample is set to No tray.

An 'Apply' button is located at the bottom right of the dialog.

Detector Initial Conditions (All Methods)

Figure 2.2 Instrument Setup - PDA Detector

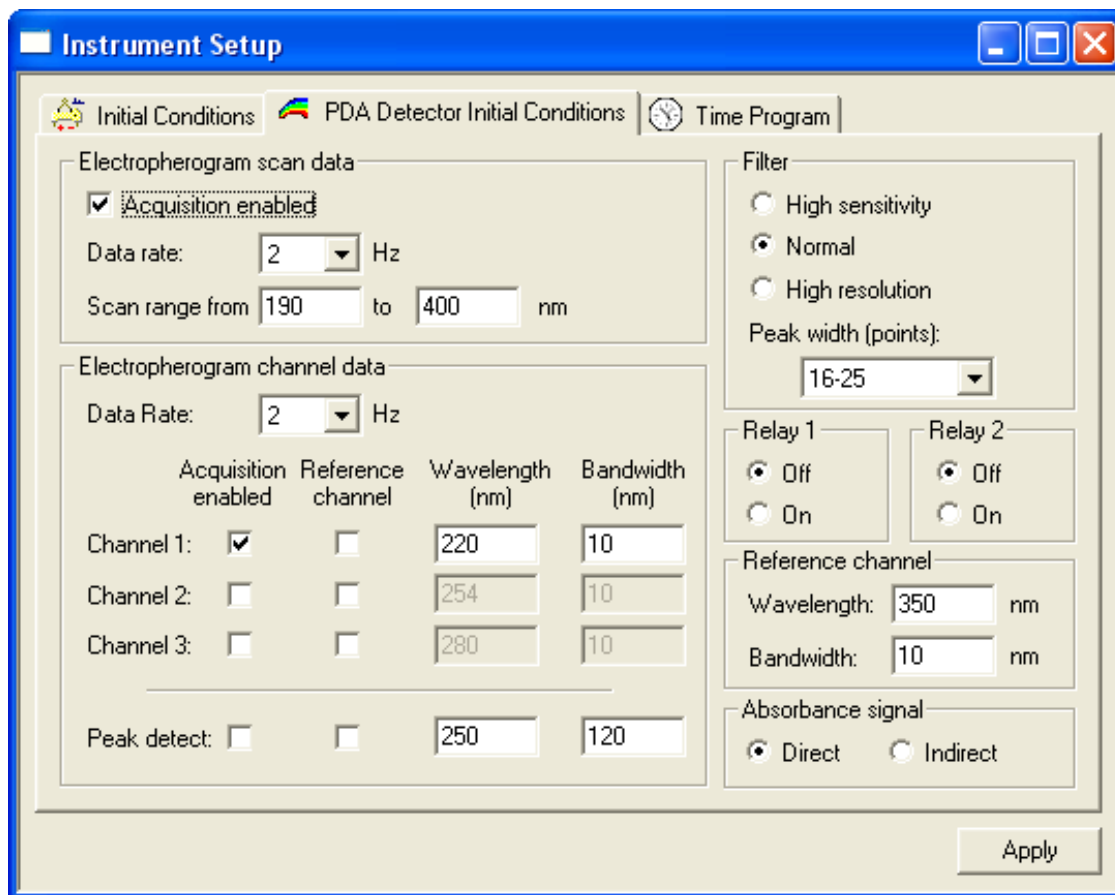

NOTE UV absorbance spectra across the entire separation will be obtained if acquisition is enabled on the electropherogram scan data. This feature facilitates the identification of proteins and other UV absorbing molecules.

Capillary Conditioning Method (SDS MW Conditioning - PA 800 plus.met)

A new capillary or a used capillary that has been stored for a long period of time must be conditioned using the Capillary Conditioning method before starting CE separation.

Figure 2.3 Time Program - Capillary Conditioning

Time (min)	Event	Value	Duration	Inlet vial	Outlet vial	Summary	Comments
1	Rinse - Pressure	20.0 psi	10.00 min	BI:D	BO:D1	forward	0.1 N NaOH rinse to clean capillary surface
2	Rinse - Pressure	20.0 psi	5.00 min	BI:E1	BO:E1	forward	0.1 N HCl rinse to neutralize capillary surface silanol group
3	Rinse - Pressure	20.0 psi	2.00 min	BI:F1	BO:F1	forward	ddH2O rinse to remove the acid residue
4	Rinse - Pressure	70.0 psi	10.00 min	BI:B1	BO:B1	forward	SDS Gel rise to fill the capillary
5	Separate - Voltage	15.0 KV	10.00 min	BI:C1	BO:C1	5.00 Min ramp, reverse polarity, both	SDS Gel for voltage equilibration
6							

SDS-MW Separation Method

Figure 2.4 SDS MW Separation - PA 800 plus.met

Time (min)	Event	Value	Duration	Inlet vial	Outlet vial	Summary	Comments
1	Rinse - Pressure	70.0 psi	3.00 min	BI:D	BO:D1	forward, In / Out vial inc 8	0.1 N NaOH rinse to clean capillary surface - Automatic increment every 8 runs
2	Rinse - Pressure	70.0 psi	1.00 min	BI:E1	BO:E1	forward, In / Out vial inc 8	0.1 N HCl rinse to neutralize capillary surface silanol group - Automatic increment every 8 runs
3	Rinse - Pressure	70.0 psi	1.00 min	BI:F1	BO:F1	forward, In / Out vial inc 8	Water rinse to remove the acid residue - Automatic increment every 8 runs
4	Rinse - Pressure	70.0 psi	10.00 min	BI:B1	BO:B1	forward, In / Out vial inc 8	SDS Gel rinse to fill the capillary with SDS gel - Automatic increment every 8 runs
5	Wait	0.00 min	0.00 min	BI:A1	BO:A1	In / Out vial inc 8	ddH2O, use for dipping to clean capillary tip - Automatic increment every 8 runs
6	Wait	0.00 min	0.00 min	BI:A4	BO:A4	In / Out vial inc 8	ddH2O, use for dipping to clean capillary tip - Automatic increment every 8 runs
7	Inject - Voltage	5.0 KV	20.0 sec	SI:A1	BO:C1	Override, reverse polarity	Sample injection
8	Wait	0.00 min	0.00 min	BI:B4	BO:B4	In / Out vial inc 8	ddH2O, use for dipping to avoid sample carry over - Automatic increment every 8 runs
9	Separate - Voltage	15.0 KV	30.00 min	BI:C1	BO:C1	1.00 Min ramp, reverse polarity, both, In / Out vial inc 8	SDS Gel for separation - Automatic increment every 8 runs
10	Autozero						
11							

Shutdown Method

Figure 2.5 SDS MW Shutdown - PA 800 plus

Time (min)	Event	Value	Duration	Inlet vial	Outlet vial	Summary	Comments
1	Rinse - Pressure	70.0 psi	10.00 min	BI:D	BO:D1	forward	0.1 N NaOH rinse to clean capillary surface
2	Rinse - Pressure	50.0 psi	5.00 min	BI:E1	BO:E1	forward	0.1 N HCl rinse to neutralize capillary surface silanol group
3	Rinse - Pressure	50.0 psi	2.00 min	BI:F1	BO:F1	forward	Water rinse to remove the acid residue
4	Rinse - Pressure	70.0 psi	10.00 min	BI:B1	BO:B1	forward	SDS Gel rinse to fill the capillary with SDS gel
5	Separate - Voltage	15.0 KV	10.00 min	BI:C1	BO:C1	5.00 Min ramp, reverse polarity, both	SDS Gel for separation
6	Wait		0.00 min	BI:A1	BO:A1		ddH2O use for capillary dip to prevent capillary from drying
7	Lamp - Off						
8							

www.beckmancoulter.com and
www.CELeader.com

